

CARE & MAINTENANCE FOR YOUR

# One Touch Umbrella



## CARE & MAINTENANCE FOR YOUR

# One Touch Umbrella

As durable as the One Touch Umbrella is, it needs to be looked after as it's not indestructible. It needs to be protected from high winds and needs to be maintained, especially if it's exposed to coastal conditions. These harsh conditions will cause it to rust if it is not maintained in the correct manner. Please read these maintenance instructions carefully.

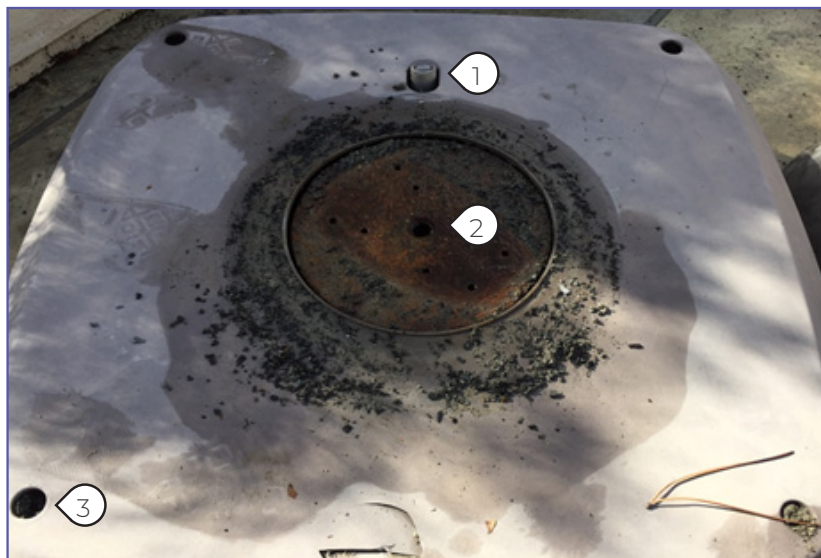

This is an OTU base which has rusted due to sea air (salinity) and a clear indication that it hasn't been maintained correctly.

1. Foot stopper with spring.
2. Swivel mechanism.
3. Screw wells with wheels.

## HOW TO CARE FOR YOUR ONE TOUCH UMBRELLA

1. **Foot stopper** – The foot stopper is pressed when swivelling the umbrella 360 degrees. For this to continue working efficiently it needs to be maintained. The mechanism has a metal spring which needs to be lubricated and protected from rust using a rust preventer. If moisture enters this area it will rust over time. By using a rust preventer, the lifespan of the spring will be a lot longer. If you live on the coast, it is recommended that this is done weekly due to the harsh conditions.

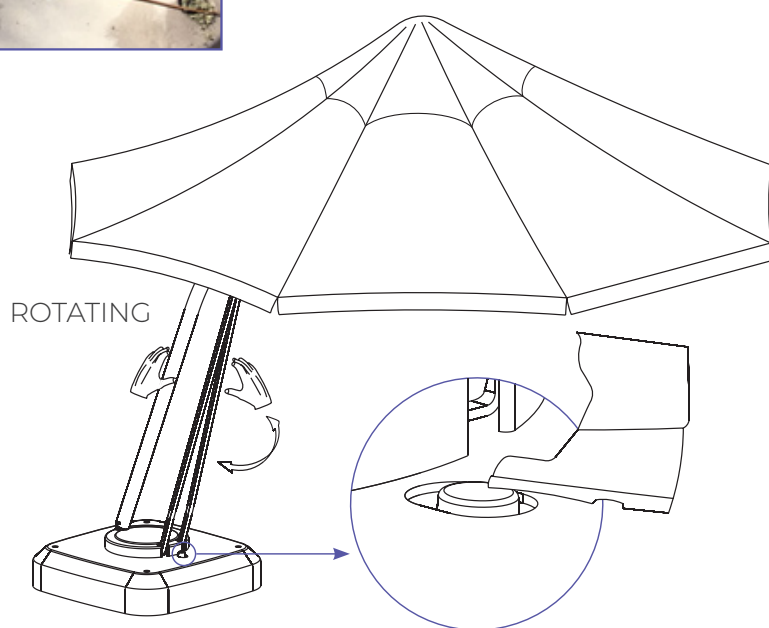

2. **Screw wells with wheels** – The screw wells come with round plastic caps which prevent water from entering them. If these caps are not kept on top of the wells, water and moisture collects inside the wells, causing them to rust. Do ensure the plastic caps are always in place to prevent this.

There are wheels connected to the end of the screw well, which make it easy to move the base around. The screw wells need to be lubricated on a regular basis to prevent rust from setting in and need to be turned regularly to ensure that they are kept loose and in good working order. If you live on the coast, it is recommended that this is done weekly due to the harsh conditions.

When you want to move the umbrella, lower the wheels and move it into your desired location, but remember the wheels always need to be screwed back into the base when the umbrella is stationary so that it doesn't move due to wind. This also protects the wheels from being exposed to moisture.

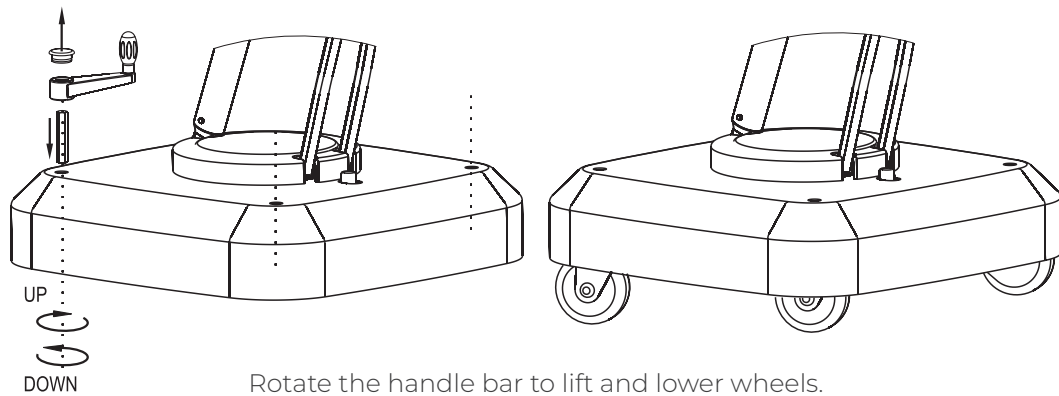

3. **Swivel Mechanism** – This part turns 360 degrees and works with ball bearings and a gear which holds it in place when your umbrella is stationary. If the swivel mechanism isn't lubricated regularly, it will eventually rust. Spray the lubricator/rust preventer around the circumference of the swivel mechanism so that it goes into the gears and ball bearings. If you live on the coast, it is recommended that this is done weekly due to the harsh conditions. (To see how to swivel the umbrella see the image that says rotating)

Always ensure that your protective canopy is used when the umbrella isn't in use. The protective cover is there to do just that, protect the canopy of the umbrella from the elements and UV degradation.

Please read about our product guarantees on our website. ([www.mobelli.co.za/guarantee](http://www.mobelli.co.za/guarantee))

**What is not covered by the guarantee:**

- Damage caused by wind
- Damage caused by misuse
- Damage caused by negligence
- Damaged caused by wear and tear
- Damage caused in an environment with harsh conditions

## WHEN ITS WINDY:

We always recommend when it's windy you close your umbrella and put the protective cover on. Move your umbrella to the least windy and most protected area of your patio or outside space to help avoid wind damage.

## ON A GENERAL NOTE:

Mobelli outdoor furniture is easy to use and generally requires little maintenance. However this does not mean the furniture is indestructible. Certain environmental elements may damage your furniture and invalidate your guarantee.

Please protect your furniture specifically from the effects of wind. If you live in a windy area, be aware when the wind comes up and take precautions to ensure that the furniture does not get damaged.

Please note that every product has a limited life span. The Southern African sun, in particular is incredibly harsh and leads to faster deterioration of outdoor furniture than, say, in Europe. Treat your furniture with care and your investment will last longer.

Redefining the value of style

**mobelli.co.za | 0861 66 23 55**

Paarden Eiland | Sea Point | Illovo | Fourways | Umhlanga Ridge